

Lubricant management for non-circulating sumps

Failing to follow these simple measures likely will lead to shortened life expectancy for high-criticality machines.

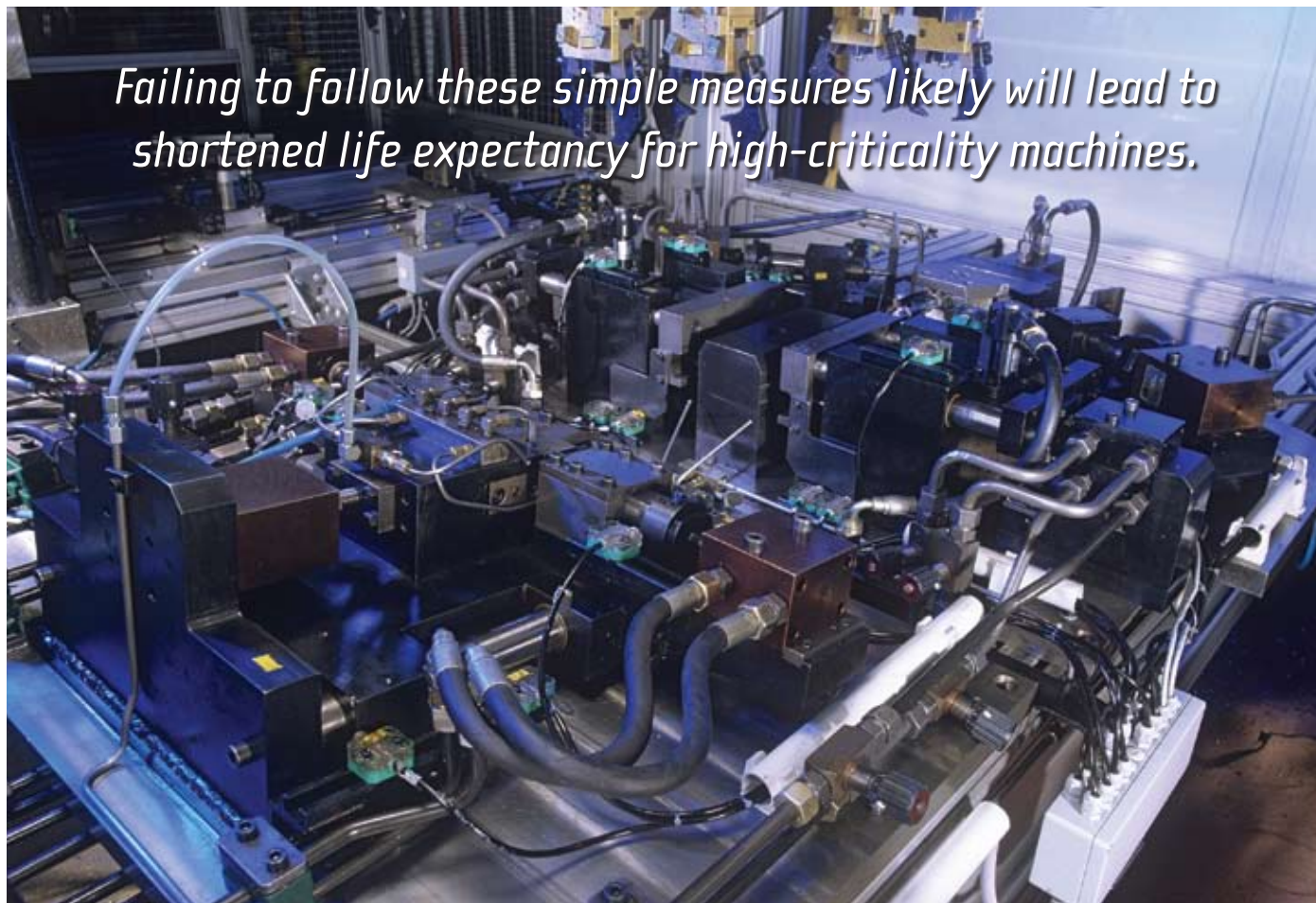

KEY CONCEPTS:

- Lubricant degradation starts with poor lubricant condition control.
- Ingression at vent ports and shaft seals and poor lubricant handling contribute significantly to lubricant degradation.
- Lubricant conditioning with side-stream filters should be a routine PM activity for all critical sumps, regardless of sump volume.

Lubricant management could mean a variety of different things to different people within a facility. The maintenance planner or lube crew supervisor may view lubricant management as the process that assures that all the machines scheduled for level checks, replenishment and oil changes are serviced in a timely manner. The condition control technician may view this as sample collection for analysis and long-term planning. Each would be correct. The intent for this article is to address yet another aspect of the interesting world of reliability centered lubrication: sump condition control for static sumps.

NON-CIRCULATING OIL SUMPS

A non-circulating or static sump is one where the lubricant remains with the components. The sump isn't static in the

A non-circulating or static sump is one where the lubricant remains with the components.

sense that it lacks motion. The lubricant certainly moves around the components under protection. In this instance, the static sump is one where the lubricant remains with the sump during operation, in contrast to the dynamic sump where the lubricant drains or is pumped out of the fixture holding the components and is later returned.

Static sumps for industrial machines tend to be simple enclosures surrounding moving components. Equipment owners typically do not specify standards for seals, filters, heat limits, moisture control, sump volumes or port dimension and location when placing a bid for simple machines with small sumps. Consequently, simple assemblies like gear drives and bearing enclosures tend to be exposed to the environment through open vent ports and shaft seals. Machines with complex design or operational parameters (very high or very low speeds, high loads, high temperatures, environmental extremes, etc.) tend to incorporate forced circulation and supply in the design details and suffer less from incomplete design. It is common to have high criticality rankings assigned to static sumps. It is common for these sumps to build up particularly high contamination loads. Unless effort is applied to controlling contaminant exposure, the associated components will have shortened lifecycles.

CONTROLLING LUBRICANT HEALTH

There is a large body of research suggesting that many common wear problems are associated with overall lubricant condition and cleanliness. Oil- and grease-lubricated machines that operate with continuous environmental challenges and without the benefit of sump health controls experience short lifecycles and high repair costs.

Bearing manufacturers have to their credit advertised failure causes for bearings, and encouraged customers to focus on underlying causes. Figure 1 illustrates this well.

The Unsuitable Lubricant category includes such problems as the wrong viscosity selection and wrong additive

types. Aged Lubricant suggests degradation. The contamination challenges include: moisture, air, heat, machine wear debris and particulate from the facility's atmosphere.

These problems are present to the extent that they can be overwhelming. Coincidentally, these two categories of problems are self-perpetuating. Increases in contaminant loads

Figure 1 | Common contributors to bearing degradation.

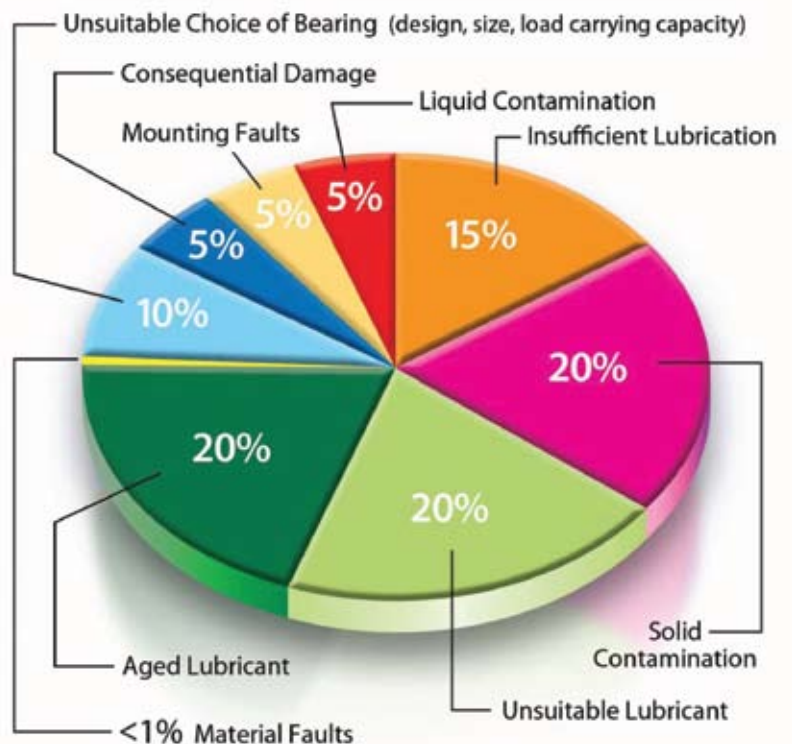

lead to increases in wear debris, which accelerates the oxidation cycle, which weakens the lubricant, which can contribute directly to more wear debris, perpetuating the cycle.

Contamination control may be the single largest area for improvements from the implementation of precision lubrication practices.

CONTAMINANTS REVIEWED

Industrial sites are ripe with contamination sources. The most common problems come from the air we breathe—moisture, particulate, heat and the air itself. Temperature changes occurring with normal ambient temperature differences, or with normal operating cycles, cause the machine to breathe. Although the movement is slight, contaminants from the air settle into the oil and remain until forcibly removed or drained from the sump. Through daily thermal cycles over an extended period of time, the resident contami-

Contamination control may be the single largest area for improvements from the implementation of precision lubrication practices.

With small sumps, prevention is much easier than removal.

nant load can become significant. Unfortunately, because the failure modes are slow, it is difficult to see the damage caused by most contaminants until well past an appropriate time to act.

Let's look at these sources more closely.

Moisture. Water contamination is the fuel that propels oil and machine destruction. Moisture accelerates wear through corrosion from direct contact with surfaces, corrosion from chemical changes in the oil (particularly for AW and EP oils) and by increasing the risk of film collapse under load. Condensation can form on the underside of tank lids, create rust and, thereby, add to solid contaminant loads. Moisture also promotes vaporous cavitation and destruction of pump surfaces.

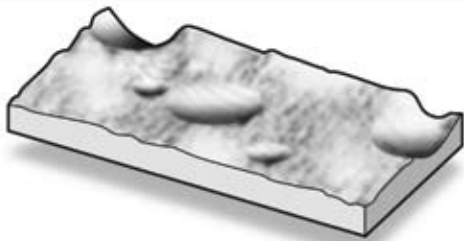

Figure 2 | Surface damage typical from wear debris.

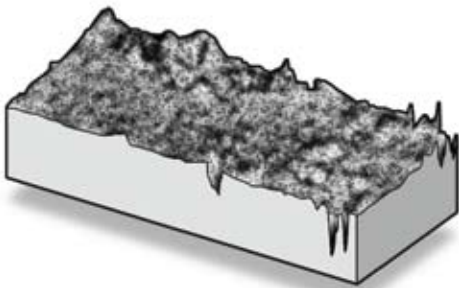

Figure 3 | Surface damage typical from atmospheric debris.

Particulate. Particles promote micropitting, fatigue and three-body wear in proportion to their concentration in the oil. The solid particle sizes that impose the greatest threat to machine surfaces, those that are small enough to get between the surfaces and bridge the oil film gap, are well below that which can be seen without the use of a microscope. Add to this the fact that particles become more difficult to crush as

the size decreases. Particles that are one to three microns in size are particularly tough, and particularly destructive to machine surfaces.

Figures 2 and 3 depict the impact from contaminants on machine surfaces, denoted by whether it's particulate from machine wear (Figure 2) or from atmospheric dust (Figure 3). Atmospheric dust can change the surface profile of the machine component if the hardness of the particle is greater than that of the component steel. Silica-laden atmospheric dust can have a greater hardness rating than many machine steels. When dust particles fracture to a size small enough to enter the dynamic clearances (± 2 microns) at component contact interfaces, these hard, tough particles can cause jagged indentions in the surface profiles. Wear debris particles, existing at the higher particle counts mean higher wear rates—for all types of lubricated components. As wear increases, the catalytic effect of iron and copper debris accelerates chemical reactions and increases the rate of aging.

Air. Air provides oxygen, the other fuel, which promotes chemical reactions and drives the aging process. About 10% of the volume of a container of oil is dissolved air. This is a natural state and is tolerated in formulation decisions, but it is problematic in higher percentages.

Air entrainment or saturation can occur in static systems when the level is too high or too low, when the lubricant is contaminated by water and process chemicals and as a consequence of lost air removal additives.

Heat. Excess heat makes all of the previously noted problems bigger. The Arrhenius rate rule in organic chemistry tells us that chemical reaction rates double with each 10 C temperature increase. Following that logic, as sump temperatures increase the aging process increases, doubling with each 10 C increase.

Additionally, heat is added from surface friction, from cavitation, and from shear stress on the oil film as it thickens under pressure.

PREVENTING CONTAMINATION

With small sumps, prevention is much easier than removal. Prevention of contaminant ingress for pumps, small drives, bearing housings and other low-volume sumps revolves around exclusion at the shaft seal points, vent ports and cleaning the lubricant handling and top-up activities.

Vent port improvements. OEM-provided vent filters are typically not designed to arrest airborne contaminants. Vent covers are constructed from metal mesh. Even a 200-mesh screen, which would be considered to be high quality, is porous, limiting particles that are 75 microns and greater. Covered screens may slow ingress from blowing wind

and rain but not to a great extent.

Upgrades to vent ports are simple and low cost. Where machines operate within proximity to high humidity (70% relative humidity or greater), vents should be upgraded to desiccant vent filters. The dominant suppliers provide models that incorporate high quality (≥ 5 micron target size) media at the point of air entrance to increase the value of a desiccant element purchase.

Low-humidity applications would benefit from retrofitting to either desiccant or non-desiccant type elements, but the reliability engineer should be conscious of selecting an element that provides a dramatic improvement from the status quo. Automotive oil filter elements target relatively large particles ($\beta_{35} = 90$) and, accordingly, are not the best choice

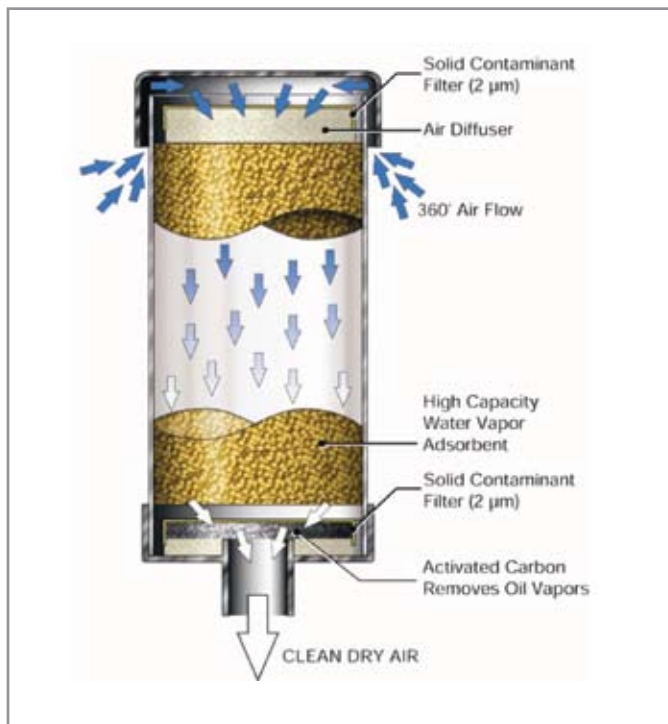

Figure 4 | Desiccant elements can be used to arrest airborne contaminant ingress at a relatively low cost. (Courtesy of Trico Corp.)

for production machines oil filtration, but these same elements ported to allow bi-directional air movement provide adequate capture effectiveness for low-particle velocity air flow. Figure 4 provides a cross section view and illustrates the air flow through a desiccant element.

It is a long-standing failure of machine design strategies to place open pipes or screens at vent port locations. The relative cost to close this point of intrusion could run as high as a couple hundred dollars per machine for the initial installation (including labor) and another hundred dollars per year for replacements if high quality desiccant elements are used. The benefit, in the form of extended component and lubricant lifecycles, can easily outweigh the cost.

Shaft seal improvements. Shaft seal points represent likely points for solid and moisture contaminant ingress. Figure 5 represents a typical lip seal configuration. Lip seals have a contact fit with the shaft and, by design, press against the shaft during operation. The subtle movement of the seal from normal radial contact with the shaft causes the seal to flex slightly to perform a subtle pumping motion. Lip seals are intended primarily to hold in the lubricant.

Seal longevity is directly influenced by heat, solid contaminants at the shaft-to-seal interface and by chemical attack due to normal lubricant leaching effects. If operating in climate-controlled conditions, such as a clean room condition required for the manufacture of computer chips, the simple lip seal may function for several thousand hours. Sumps operating within high contaminant areas can experience loss of seal integrity in a couple hundred hours.

Bearing isolators, as shown in Figure 6, provide a significant reduction in risk of moisture or airborne contamination ingress across the shaft. Bearing isolators maintain a tight fit with both the housing and the shaft, and only experience rubbing contact between the stator and rotor. This allows for better lubricant sealing and better contaminant prevention.

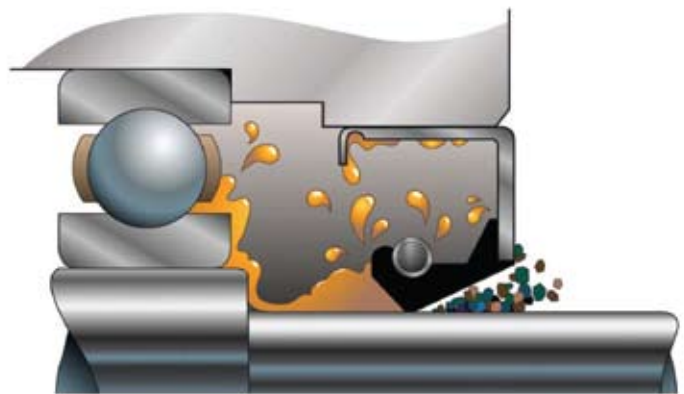

Figure 5 | Heat, solid contaminants and rubbing contact degrades lip seals.

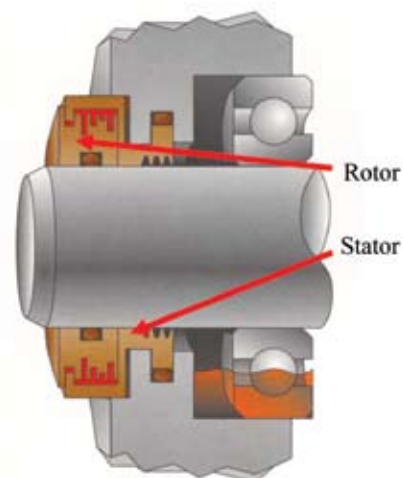

Figure 6 | A typical bearing isolator. (Courtesy of AES Seals)

NOW AVAILABLE!
Ask about our Electronic Version!

Simple, Accurate, Intuitive, Shop-Floor Ready, and Maintenance Budget Friendly

Optimize Your Grease Lubrication Practices...

COMING SOON!
LubeCoach for your iPhone or Smartphone



...in minutes,
instead of hours.



No more calculators and worksheets needed to assign the correct volume and frequency to your grease lubricated element bearings.

No Training Required! *If you can estimate the bearing type, shaft speed and size – you can make the right call instantly.*



For more information visit us online at www.PrecisionLubrication.com for technical details and to place your order today.



Now available for Ball Bearings, Cylindrical Bearings, and Spherical Bearings.

A high percentage of finished lubricants arrive at the plant site in a state that is unacceptably dirty for high-criticality machines.



Proactive sump management provides protection to both component and lubricant, extending expected lifecycles.

Figure 7 | Prefiltering lubricants into a machine sump is a reliability-centered world class quality practice.

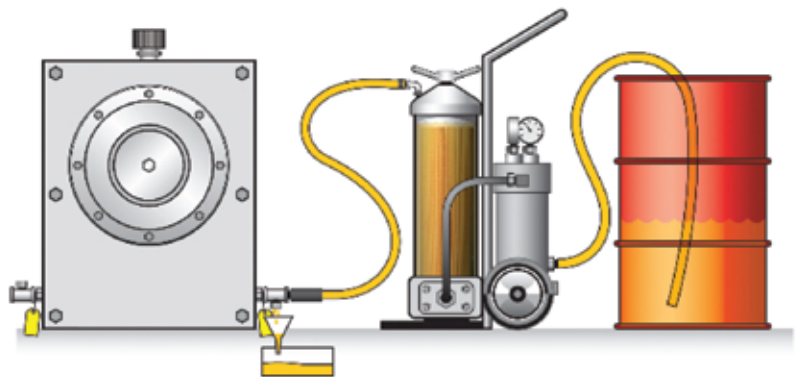
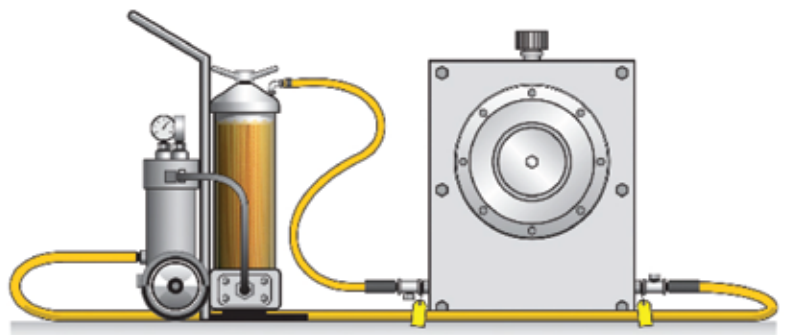

Figure 8 | Side-stream filtration is a practice designed to clean the lubricant while it's in use.



LUBRICANT HANDLING AND TOP-UP ACTIVITIES

Routine lubricant handling practices is an easy third choice for improving lubrication management practices. Lubricants shipped in bulk from blend plant to a local vendor, and then repackaged or shipped in a bulk truck, to the local customers are subject to tremendous variability in cleanliness quality. Vessels, including pails, kegs, drums, totes and bulk trucks, are universally expected to be “clean enough” for end-use, but, in fact, they are not for many modern manufacturing systems. The major brands recognize the potential for corruption of the lubricant by the container and have developed rigorous practices for evaluating and condemning questionable containers.

But is that enough?

As it turns out, even following this practice, a high percentage of finished lubricants arrive at the plant site in a state that is unacceptably dirty for high-criticality machines. This does not suggest that the lubricant pumped into the auger type trash compactor is too dirty for safe use. However, the lubricant intended for the plastic injection molding hydraulic system with pressure compensated variable volume piston pumps and servo controls operating at 3,300 PSI, should be serviced before it goes into use.

Preconditioning lubricants before use is simple and relatively inexpensive. World-class manufacturers moved in this direction several years ago through the use of simple side-

Preconditioning lubricants before use is simple and relatively inexpensive.

stream filter systems employing high-efficiency, low-particle size media. Figure 7 illustrates the concept of prefiltering the lubricant as it is being placed into the machine sump. High-capture efficiency elements ($\beta_x = 100$; = 99%) collect nearly all of the targeted particle size as the particles enter the element. Theoretically, some high efficiency elements remove all but .01% of the particles at and larger than the tar-

get particle size. This is immensely beneficial to the machine receiving the lubricant.

Following initial fill conditioning, the same system can be used to treat the oil in the machine sump while the machine is running. Figure 8 illustrates the use of the same filter system for long-term improvement of fluid operating conditions. The same type of device can and should be used

to control water. The same approach can be used to control moisture, although specialized vacuum distillation systems are more effective than water-removal element inserts.

Side stream filtration should be scheduled as a routine PM practice for all sumps that have (1.) high-criticality rankings, (2.) a high potential repair charge, (3.) large sump capacity or (4.) contain components that are sensitive to microscopic contaminants or moisture.

SUMMARY

Proactive sump management provides protection to both component and lubricant, extending expected lifecycles. Common contaminants that degrade the lubricant include atmospheric air, moisture, dust and heat. Vent breathers are useful at preventing much of the contamination from air. Replacing lip seals with bearing isolators helps limit ingress across the shaft to housing interfaces. Prefiltration of lubricant is necessary for high-criticality machines. Side-stream filtration should also be used systematically as a machine PM to improve fluid conditions and protect machine health. **TLT**



Mike Johnson, CLS, CMRP, MLT, is the principal consultant for Advanced Machine Reliability Resources, in Franklin, Tenn. You can reach him at mike.johnson@precisionlubrication.com.

Charting Your Course To Productivity Begins With KNOWLEDGE

Contact AMRRI today for a complete list of upcoming Precision Lubrication Training Seminars.

ICML Certification available: MLT-1, MLT-2, and MLA-1



www.PrecisionLubrication.com

